

FITTING INSTRUCTIONS

(“SINGLE SEATER” version)

ATTENTION: before carrying out any work on the exhaust, check that its surface has cooled so that it will not damage components, which are not heat-resistant (such as fairing, hoses, rubber sleeves, etc.), or the operator.

- 1.** Remove the OE silencer(s)
- 2.** Check that the mating surfaces are in good clean condition, slide the link pipe on to the original header, taking care not to damage the graphite gasket (if supplied) which should replace the OE gasket. Partially tighten the securing strap to allow a degree of further adjustment.
- 3.** Slide the Leovince SBK silencer onto the link pipe, check the alignment of the mounting eyes for the springs and the alignment of the exhaust outlet to the rear of the silencer, and then link the parts together with the springs provided
- 4.** Fit the carbon strap(s) to the silencer(s); mount spacers, washers and brackets (if any) as shown on the drawing and then secure by tightening nuts and bolts.
- 5.** Tighten the various clamps which join the Leovince SBK link pipe(s) to the OE exhaust headers.
- 6.** Start the engine, wait a few minutes until it reaches operating temperature, and check that there are no gas leaks.

IMPORTANT: During the first km of running, the exhaust system needs breaking-in; therefore, slight gas leakage might occur. After approximately 100 Km, check all the fasteners.

ADJUSTMENT:

This silencer has been developed by Leovince on an electronic test bed using a machine in perfect condition, and in standard trim.

MAINTENANCE:

From time to time, check all the brackets and fasteners, which could be affected by use (sound-deadening material, seals and other rubber parts) and replace them periodically. The silencer may be cleaned using gasoline, diesel oil or alcohol. Absolutely avoid the use of any kind of solvent. It is normal for there to be some discolouration of the silencer, which is the result of heat and the nature of the materials used.

IT IS FORBIDDEN to modify silencers. Whatever form this may take, SITO GRUPPO INDUSTRIALE declines any responsibility for defects, problems, or malfunction, arising from the use of any product which has been modified or tampered with.

WE SUGGEST THE FITTING TO BE MADE BY PROFESSIONALS

TECHNICAL DRAWING

I - Asportare definitivamente le pedane passeggero e al posto della pedana destra fissare la staffa (**ref. 4**) fornita in confezione utilizzando la minuteria "LeoVince".

GB - Finally remove the passenger footboards and, in place of the righthand footboard, secure the bracket (**ref. 4**) included in the kit, using the "LeoVince" findings.

F - Enlever définitivement les appuie-pieds du passager et remplacer l'appuie-pied droit par la bride (**réf. 4**) fournie dans le kit, en employant la minuterie d'origine.

D - Die Beifahrer-Fußbretter entfernen und an Stelle des rechten Fußbrettes den mitgelieferten Bügel (**Bez-Nr. 4**) durch die beigelegten „LeoVince“- Verschraubungen befestigen.

E - Extraer definitivamente las tarimas del pasajero y, en el lugar de la tarima derecha, fijar el estribo (**ref. 4**) entregado en la confección utilizando los accesorios "LeoVince".

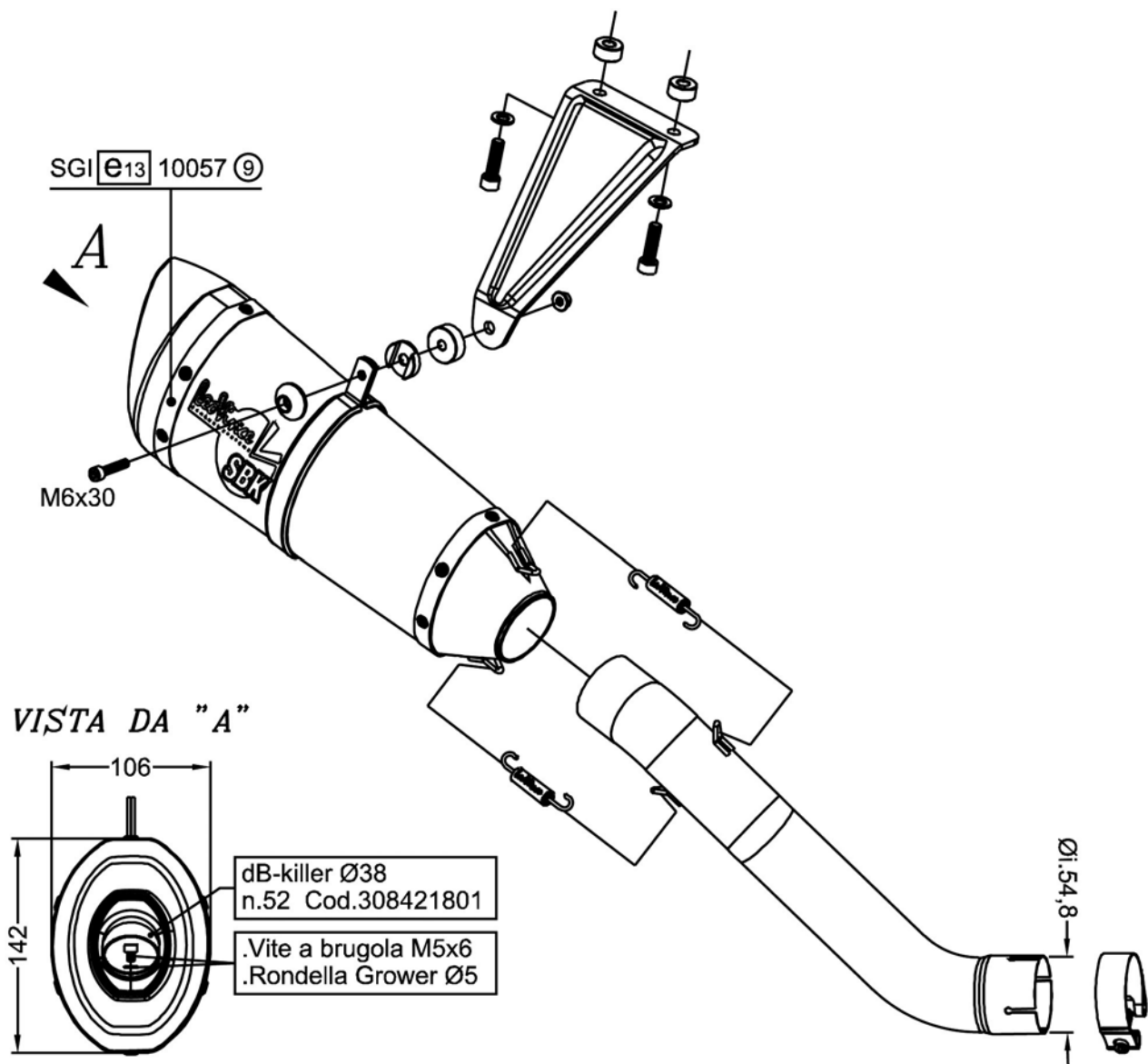

FITTING INSTRUCTIONS

(“ROAD” version)

ATTENTION: before carrying out any work on the exhaust, check that its surface has cooled so that it will not damage components, which are not heat-resistant (such as fairing, hoses, rubber sleeves, etc.), or the operator.

1. Remove the OE silencer(s)
2. Check that the mating surfaces are in good clean condition, slide the link pipe on to the original header, taking care not to damage the graphite gasket (if supplied) which should replace the OE gasket. Partially tighten the securing strap to allow a degree of further adjustment.
3. Slide the Leovince SBK silencer onto the link pipe, check the alignment of the mounting eyes for the springs and the alignment of the exhaust outlet to the rear of the silencer, and then link the parts together with the springs provided
4. Fit the carbon strap(s) to the silencer(s); mount spacers, washers and brackets (if any) as shown on the drawing and then secure by tightening nuts and bolts.
5. Tighten the various clamps which join the Leovince SBK link pipe(s) to the OE exhaust headers.
6. Start the engine, wait a few minutes until it reaches operating temperature, and check that there are no gas leaks.

IMPORTANT: During the first km of running, the exhaust system needs breaking-in; therefore, slight gas leakage might occur. After approximately 100 Km, check all the fasteners.

ADJUSTMENT:

This silencer has been developed by Leovince on an electronic test bed using a machine in perfect condition, and in standard trim.

MAINTENANCE:



From time to time, check all the brackets and fasteners, which could be affected by use (sound-deadening material, seals and other rubber parts) and replace them periodically. The silencer may be cleaned using gasoline, diesel oil or alcohol. Absolutely avoid the use of any kind of solvent. It is normal for there to be some discolouration of the silencer, which is the result of heat and the nature of the materials used.

IT IS FORBIDDEN to modify silencers. Whatever form this may take, SITO GRUPPO INDUSTRIALE declines any responsibility for defects, problems, or malfunction, arising from the use of any product which has been modified or tampered with.

WE SUGGEST THE FITTING TO BE MADE BY PROFESSIONALS

TECHNICAL DRAWING

PEDANA PASSEGGERO DX
PASSENGER'S R.H. FOOTBOARD

SGI  10057 

A

VISTA DA "A"

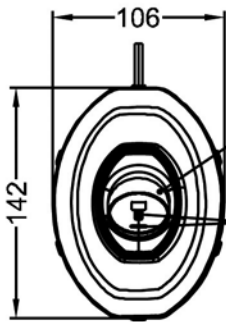

- dB-killer Ø38
n.52 Cod.308421801
- .Vite a brugola M5x6
- .Rondella Grower Ø5

Ø1.54,8

